



The Best Defense Against Surges



ZNP™

ZHP™

ZRP™

Moisture Can't Penetrate
Surges Can't Get Past



MACLEAN POWER SYSTEMS

- Direct Mold-On Housing
- Zero Air Space
- Ultimate Moisture Seal: Longer Life
- Lower Operating Costs
- Efficient Design: Fewer Parts
- Higher Reliability: Fewer Outages
- Patented Design

ZNP/ZHP/ZFP Durability

Zforce arresters are tested in accordance with ANSI/IEEE C62.11-1999 and IEC 99-4 for metal oxide arresters, and meet or exceed these minimum design criteria:

ZNP

- High-Current Short Duration: 2 current surges of 65 kA magnitude and 4/10 microsecond wave shape.
- Low-Current Long Duration: 20 current surges of 150A magnitude and 2000 microsecond duration.

ZHP & ZFP

- High-Current Short Duration: 2 current surges of 100 kA magnitude and 4/10 microsecond wave shape.
- Low-Current Long Duration: 20 current surges of 250A magnitude and 2000 microsecond duration.

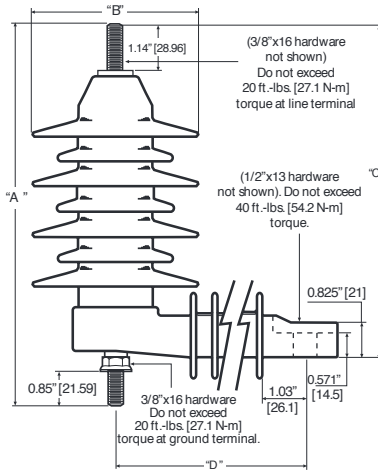

TOV Graph and Capability 3kV to 36kV

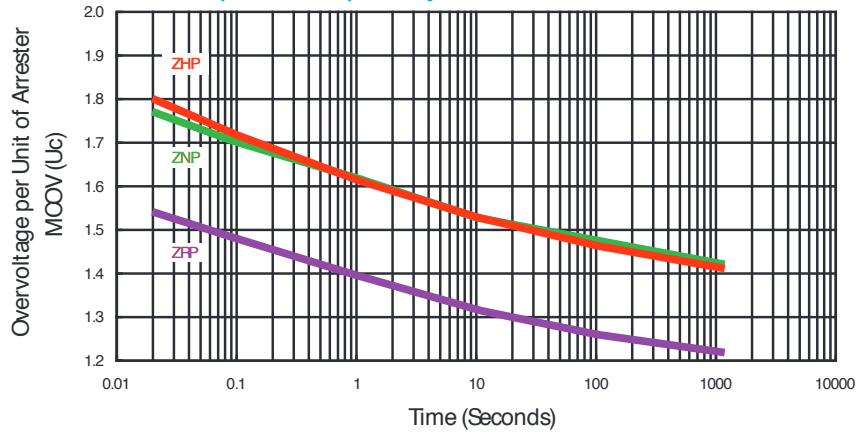

Insulated Bracket Data

Arrester Rating (kV)	Creepage		Skirts	E		F		G (Radius)	
	Inch	mm		Inch	mm	Inch	mm	Inch	mm
3-15	4.6	117	3	1.875	47.62	2.70	66.58	1.312	33.34
18-36	9.16	232	6	2.13	54.10	2.95	74.93	1.656	42.06

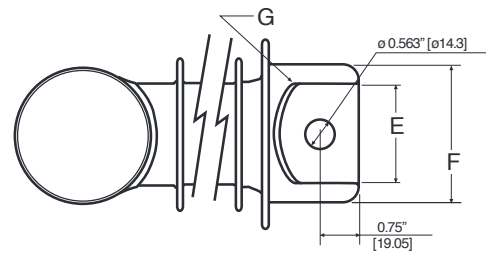

Zforce ZNP™ (5kA Normal Duty Polymer)

Physical Data

kV	Creepage ¹		Strike		A		B		C		D		Weight ²		Std. Pkg.
	Inch	Mm	Inch	mm	Inch	mm	Inch	mm	Inch	mm	Inch	mm	Lbs.	kg	
9	15.04	382	7.69	195	8.83	224	4.00	102	7.71	195	3.93	100	2.9	1.32	5
10	17.41	442	8.00	203	9.14	232	4.00	102	8.02	204	3.93	100	3.0	1.36	5
18	26.59	675	11.23	285	12.23	311	4.00	102	11.16	283	5.43	138	4.8	2.18	5

Protective Characteristics

Voltage Rating (Ur) (kVrms)	MCOV (Uc) ³ (kV rms)	Max. Equiv. FOW ⁴ (kV Crest)	Max. Switch Surge ⁶ (kV Crest)	Max. Discharge Voltage (kV Crest) Using an 8/20 μs Current Impulse						
				1.5 kA	2.5 kA	3.0 kA	5.0 kA	10 kA	20 kA	40 kA
9	7.65	29.9	23.7	25.4	26.2	26.6	28.2	30.5	33.8	39.9
10	8.4	32.9	26.3	28.1	29.2	29.6	31.3	33.9	37.4	43.9
18	15.3	59.7	47.4	50.7	52.3	53.1	56.4	61.0	67.5	79.7

Zforce ZHP™ (10kA Heavy Duty Polymer)

Physical Data

kV	Creepage ¹		Strike		A		B		C		D		Weight ²		Std. Pkg.
	Inch	Mm	Inch	mm	Inch	mm	Inch	mm	Inch	mm	Inch	mm	Lbs.	kg	
3	7.96	202	5.47	139	6.52	166	4.30	109	5.40	137	3.93	100	2.3	1.05	5
6	11.94	303	6.02	153	7.66	195	4.30	109	6.54	166	3.93	100	3.0	1.37	5
9	15.92	404	7.76	197	8.80	224	4.30	109	7.68	195	3.93	100	3.6	1.64	5
10	15.92	404	7.76	197	8.80	224	4.30	109	7.68	195	3.93	100	3.6	1.64	5
12	18.28	464	8.21	209	9.14	232	4.30	109	8.02	204	3.93	100	3.7	1.68	5
15	19.90	506	8.91	226	9.94	253	4.30	109	8.82	224	3.93	100	4.2	1.91	5
18	24.24	616	10.01	254	11.09	282	4.30	109	10.02	254	5.43	138	4.9	2.23	5
21	27.87	708	11.40	290	12.23	311	4.30	109	11.16	283	5.43	138	5.9	2.68	5
24	31.85	809	12.54	319	13.37	340	4.30	109	12.30	312	5.43	138	6.5	2.96	5
27	35.83	910	13.69	348	14.51	369	4.30	109	13.44	341	5.43	138	7.1	3.23	1
30	39.92	1014	14.52	369	15.66	398	4.30	109	14.59	371	5.43	138	7.8	3.52	1
36	43.90	1115	15.51	394	16.78	426	4.30	109	15.71	399	5.43	138	8.4	3.80	1

Protective Characteristics

Voltage Rating (Ur) (kVrms)	MCOV (Uc) ³ (kV rms)	Max. Equiv. FOW ⁵ (kV Crest)	Max. Switch Surge ⁶ (kV Crest)	Max. Discharge Voltage (kV Crest) Using an 8/20 μ s Current Impulse						
				1.5 kA	2.5 kA	3.0 kA	5.0 kA	10 kA	20 kA	40 kA
3	2.55	11.5	7.5	8.4	8.6	8.7	9.2	10.2	11.6	13.7
6	5.1	23.4	15.1	17.1	17.5	17.7	18.8	20.7	23.6	27.7
9	7.65	33.5	21.6	24.4	25.0	25.4	26.8	29.6	33.8	39.7
10	8.4	36.3	23.5	26.5	27.2	27.5	29.1	32.1	36.6	43.0
12	10.2	43.5	28.2	31.8	32.6	33.0	34.9	38.5	44.0	51.6
15	12.7	54.2	35.0	39.5	40.5	41.0	43.4	47.9	54.7	64.2
18	15.3	65.6	42.4	47.8	49.1	49.7	52.6	58.0	66.2	77.7
21	17.0	70.2	45.4	51.2	52.5	53.2	56.3	62.1	70.9	83.2
24	19.5	87.9	56.8	64.1	65.7	66.6	70.4	77.7	88.7	104.1
27	22.0	98.7	63.8	72.0	73.9	74.8	79.1	87.3	99.7	117.0
30	24.4	109.6	70.9	79.9	82.0	83.0	87.8	96.9	110.6	129.9
36	29.0	131.3	84.9	95.8	98.2	99.5	105.2	116.1	132.6	155.6



Physical Data

kV	Creepage ¹		Strike		A		B		C		D		Weight ²		Std. Pkg.
	Inch	Mm	Inch	mm	Inch	mm	Inch	mm	Inch	mm	Inch	mm	Lbs.	kg	
3	7.96	202	5.47	139	6.52	166	4.30	109	5.40	137	3.93	100	2.3	1.05	5
6	11.94	303	6.02	153	7.66	195	4.30	109	6.54	166	3.93	100	3.0	1.37	5
9	15.92	404	7.76	197	8.80	224	4.30	109	7.68	195	3.93	100	3.6	1.64	5
10	15.92	404	7.76	197	8.80	224	4.30	109	7.68	195	3.93	100	3.6	1.64	5
12	18.28	464	8.21	209	9.14	232	4.30	109	8.02	204	3.93	100	3.7	1.68	5
15	19.90	506	8.91	226	9.94	253	4.30	109	8.82	224	3.93	100	4.2	1.91	5
18	24.24	616	10.01	254	11.09	282	4.30	109	10.02	254	5.43	138	4.9	2.23	5
21	27.87	708	11.40	290	12.23	311	4.30	109	11.16	283	5.43	138	5.9	2.68	5
24	31.85	809	12.54	319	13.37	340	4.30	109	12.30	312	5.43	138	6.5	2.96	5
27	35.83	910	13.69	348	14.51	369	4.30	109	13.44	341	5.43	138	7.1	3.23	1
30	39.92	1014	14.52	369	15.66	398	4.30	109	14.59	371	5.43	138	7.8	3.52	1
36	43.90	1115	15.51	394	16.78	426	4.30	109	15.71	399	5.43	138	8.4	3.80	1

Protective Characteristics

Voltage Rating (Ur) (kVrms)	MCOV (Uc) ³ (kV rms)	Max. Equiv. FOW ⁵ (kV Crest)	Max. Switch Surge ⁶ (kV Crest)	Max. Discharge Voltage (kV Crest) Using an 8/20 μ s Current Impulse						
				1.5 kA	2.5 kA	3.0 kA	5.0 kA	10 kA	20 kA	40 kA
3	2.55	10.0	6.7	7.3	7.7	7.9	8.1	9.2	10.6	12.5
6	5.1	20.2	13.4	14.7	15.5	15.9	16.2	18.5	21.2	25.1
9	7.65	27.1	18.0	19.7	20.7	21.2	21.8	24.8	28.4	33.6
10	8.4	29.8	19.8	21.7	22.8	23.4	24.0	27.3	31.3	37.0
12	10.2	36.2	24.0	26.4	27.7	28.4	29.0	33.1	38.0	44.8
15	12.7	44.8	29.7	32.6	34.3	35.1	36.0	41.0	47.0	55.5
18	15.3	53.8	35.8	39.3	41.2	42.2	43.3	49.3	56.6	66.8
21	17.0	61.3	40.7	44.7	46.9	48.1	49.2	56.1	64.4	76.0
24	19.5	71.5	47.5	52.1	54.8	56.1	57.5	65.5	75.1	88.7
27	22.0	79.4	52.7	57.9	60.8	62.3	63.8	72.7	83.4	98.5
30	24.4	89.3	59.3	65.1	68.4	70.1	71.8	81.8	93.8	110.8
36	29.0	105.9	70.4	77.2	81.2	83.1	85.1	97.0	111.3	131.4

1. Reduce creepage by 1.45 inches (36.8mm) when ordering without insulating bracket.
2. Does not include metal mounting bracket hardware.
3. MCOV=Maximum Continuous Operating Voltage that may be applied continuously between the terminals of the arrester.
4. The equivalent Front-of-Wave is the maximum discharge voltage for a 5 kA impulse current wave which produces a voltage wave cresting in 0.5 ms.
5. The equivalent Front-of-Wave is the maximum discharge voltage for a 10 kA impulse current wave which produces a voltage wave cresting in 0.5 ms.
6. Based on a switching surge current impulse of 45x90 μ s, 500 amperes.

EZ Ordering Information

Please in the form below to specify the Zforce™ product that meets your specifications.



Z_P **P0** **kV** **-** **P1** **P2** **P3** **P4** **P5** **-** **P6** **P7**

Z_P Pole Type

ZNP - Zinc Oxide **Normal** Duty 5 kA Polymer Arrester

ZHP - Zinc Oxide **Heavy** Duty 10 kA Polymer Arrester

ZRP - Zinc Oxide **Riser** Pole Polymer Arrester

P0 General Options

0 - 3/8"x16 SSTL Studs (line and ground terminals)

kV(U_r) Duty-Cycle Rating of Arrester

03, 06, 09, 10, 12, 15, 18, 21, 24, 27, 30, 36

P1 Insulating Bracket Options

- 0** - Standard Insulating Bracket with GLD
- 1** - Standard Insulating Bracket, No GLD
- 2** - No Insulating Bracket, with GLD (line arrester)
- 3** - No Insulating Bracket, No GLD (switchgear application)

P2 Additional Bracket Options

- 0** - No NEMA Brackets
- A** - Transformer Type A Bracket
- C** - Crossarm Bracket (top mounting with backstrap assembly)
- N** - Transformer Type N Bracket
- W** - Transformer Type W Bracket

P3 Top Terminal Options*

- 00** - Standard-Four corner SSTL clamp and nut
- 02** - Two four corner SSTL clamps
- 11** - 18" Insulated Wire Lead with line ring terminal/flat washer/lock washer
- 12** - 18" Insulated Wire Lead with two ring terminals/flat washer/lock washer

P4 Universal Insulating Cap (Bird Guard)

- 0** - Without Cap
- 1** - With Cap
- 2** - Fuse Kit

P5 Bottom Terminal Options*

- 00** - Standard - U clamp and nut
- 01** - Four corner SSTL clamp and nut
- 02** - Two four corner SSTL clamps, (up/down)
- 12** - 12.0" Copper Strap

P6 Bagging Options

- B** - Boss Mounting Hardware
- H** - Lug Mounting Hardware

P7 Packaging Options

- #S** - Single Pack Modifier required only for 30kV and 36kV ratings
- #P** - Bulk Packaging

* Top/Bottom Terminal: Fits wire ranges for aluminum or copper conductors from No. 10 solid (3.0mm dia.) through 2/0 stranded (11.0mm dia.)

Catalog Order Number Example

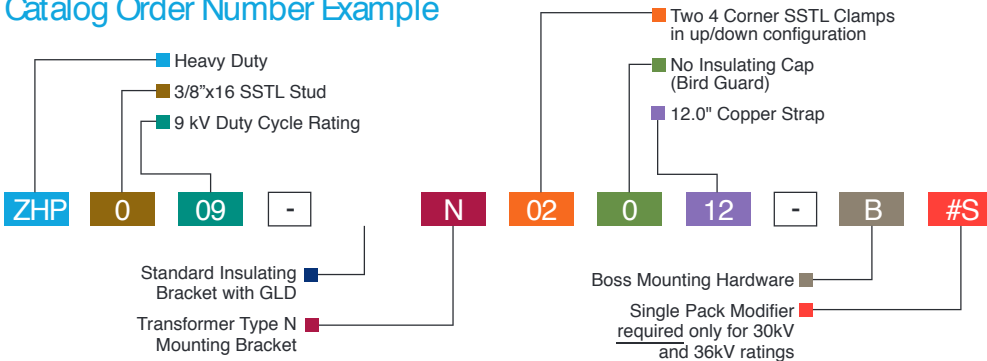

Boss Mounting Hardware



Lug Mounting Hardware

Mounting Brackets

Type "C" EEI - NEMA Top Mounted Crossarm Bracket

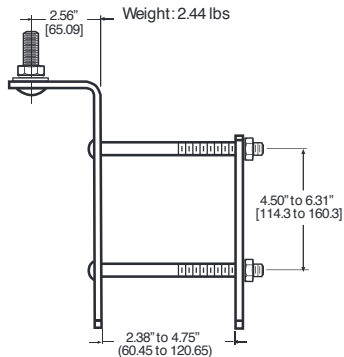

#7106A0025

Type "A" Weight: 1.08 lbs

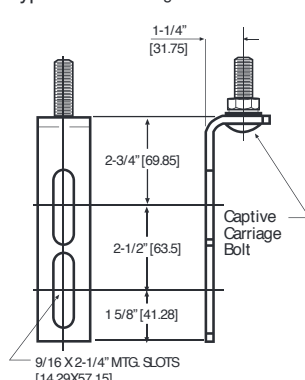

#7106A0013

Type "N" Weight: 1.39 lbs

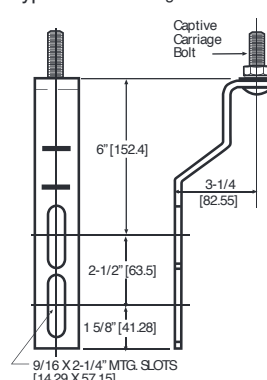

#7106A0015

Type "W" Weight: 2.09 lbs

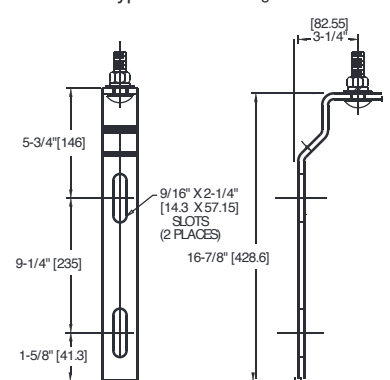

#7106A0047



11411 Addison Avenue • Franklin Park, Illinois 60131 • 847.455.0014 • FAX 847.455.0029
Visit our web site at www.macleancleanpower.com • Patent No. 5,923,518

August 2007 ©
MacLean Power Systems